

For Buderus Panel Radiator models:

- Model 21
- Model 22
- Towel Warmers

Table of Contents

1	General Info	5
<hr/>		
2	Safety	6
<hr/>		
3	Product Description	7
<hr/>		
4	Mounting Guidelines	15
<hr/>		
5	Radiator Output Ratings	17
<hr/>		
6	Radiator Selection Procedure	21
<hr/>		
7	Piping Arrangements	22
<hr/>		
8	Buderus NB Style Towel Racks	32

1. General information

1.1. This manual

This application manual is intended for engineers, architects, contractors, and installers. It provides specification on panel radiator and towel rack models, sizing information, and system layout assistance for hydronic heating systems with panel radiators.

This manual describes the basic operation of the Buderus panel radiators and towel racks, thermostatic controls and piping accessories. It also provides rough in dimensions and installation procedures.

Radiator heating capacities are listed by model, height and length and are based on different supply water temperatures.

For added savings Buderus recommends running panel radiator systems at reduced temperatures. When using a condensing boiler, the system should be designed so that the return water temperature makes the boiler condense except on the coldest days of the year.

Dew point flue gases:

- Natural Gas: 130°F (55°C)
- #2 Fuel Oil: 118°F (48°C)

General guide lines are discussed with respect to sizing and radiator selection. The design and radiator selection process for one and two pipe heat distribution systems are provided including examples. Quick and easy "rules of thumb" for trouble free installation and operation are presented.

1.2. Standards, regulations and directives

It is the responsibility of the installer to ensure that the system corresponds to all current regulations and rules.

2. Safety

2.1. Layout of the instructions

Two levels of danger are identified and signified by the following terms:

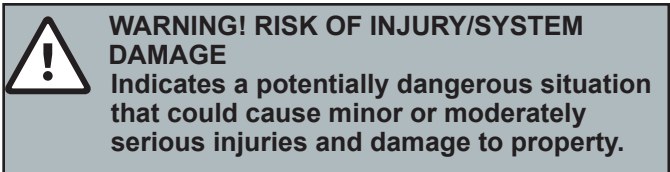
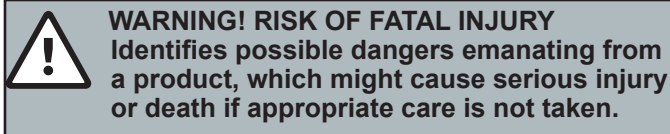

Additional symbols for identification of dangers and user instructions:



2.2. Please follow these instructions

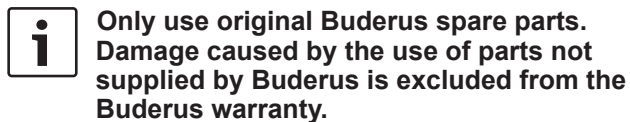

2.3. Tools, materials and accessories

For the installation of panel radiators and towel racks, you will need standard tools used for central heating, boiler and DHW water systems.

2.4. Disposal

- Dispose of the packaging in an environmentally responsible manner.
 - Dispose of defunct components through an authorized agent in an environmentally responsible manner.

3. Product Description

With the line of panel radiators Buderus offers a real alternative to conventional baseboard heating. For decades Europeans have enjoyed the unsurpassed comfort and versatility of radiant heat that is more flexible, efficient, and a cleaner alternative to baseboard heating. Unlike conventional baseboard heat that provides only convection heat, the high performance hydronic steel panel radiators provide the perfect combination of both convective and radiant heat while offering significant savings from lower water temperatures.

Radiant Heat vs. Convection Heat:

Forced hot air or baseboard systems with fin tubes produce heat that warms the air by convection, which requires high water temperatures to effectively output BTU. This results in large temperature differentials in the room, can cause drafty conditions, and in many cases results in hot air collecting at the ceiling and cooler air at floor level.

Radiant heat, like the sun, warms objects rather than just the air, creating a greater sense of warmth while requiring lower room temperatures. The added radiant component from panel radiators may permit return water temperatures below 130°F (55°C) for natural gas and 118°F (48°C) for oil fired appliances, allowing a condensing boiler to condense and take advantage of its added efficiency.

Because Buderus radiators don't turn "on and off" randomly in the way traditional baseboards do, they are virtually silent — eliminating the noise associated with other heating systems.

The flexibility of Buderus panel radiators offers builders, designers, and homeowners a variety of sizes for any heating and design requirement. These space-saving panel radiators require between a third to a quarter of the space of baseboard heating and are a perfect solution where design flexibility is important. The radiator's unique wall-mounted and optional floor-mounted styling also minimizes areas where dust and dirt can collect and allows for greater flexibility in furniture placement.

Panel radiators from Buderus are stocked in several heights and lengths, and in two widths.

Special order sizes, up to 3' high and 10' long, are available with a 4 to 6 week lead-time.

Buderus panel radiators come in a multi-layered, powder coat enamel white finish that is durable, easy to clean and ideal for most existing color schemes. They can also easily be custom painted to any desired color.

Each panel radiator includes side panels, front and back grill covers, and a flowsetter valve. This feature enables the system installer to quickly and easily regulate the water flow through the radiator room by room. The result is a consistent, even heat throughout all panel units in the house — no more feeling warm in one room and chilly in another.

Buderus Panel Radiators

Buderus "solidoflux N" panel radiators are manufactured from 18 Gauge (0.049"/0.125mm) steel panels. They consist of water filled welded steel panels with convector channels mounted on the back. These layers are combined and arranged into two basic models: model # 21 (width 2.5"), model # 22 (width 4.0").

Standard equipment with each radiator include wall mounting brackets, bottom piping connections, built in manual air vents, a drain plug and a flow setter valve with a protective cover over it.

All stocking models have the flow setter (control) valve and piping on the same side, and can be mounted facing left or right.

Available Models

Model 21		Table 1		
Dimensions	Dry weight		Water volume	
H x L x W	lbs	kg	gal	liters
12"x24"x2"	20	9	0.7	2.6
12"x36"x2"	31	14	1.0	3.8
12"x48"x2"	41	19	1.3	5.1
12"x59"x2"	50	23	1.6	6.3
12"x63"x2"	54	24	1.8	6.7
12"x71"x2"	60	27	2.0	7.6
20"x24"x2"	35	16	1.0	3.8
20"x36"x2"	52	24	1.5	5.8
20"x48"x2"	69	31	2.0	7.7
20"x59"x2"	85	39	2.5	9.4
20"x63"x2"	91	41	2.6	10.1
20"x71"x2"	102	47	3.0	11.4
24"x24"x2"	41	19	1.2	4.5
24"x36"x2"	62	28	1.7	6.7
24"x48"x2"	83	38	2.3	8.9
24"x59"x2"	102	46	2.9	10.9
24"x63"x2"	108	49	3.1	11.7
24"x71"x2"	122	56	3.4	13.2

Buderus Towel Warmers

Nothing is more comforting than a warm towel after a bath or shower. European towel warmers from Buderus are the perfect combination of contemporary styling and economical luxury. Towel warmers are also an excellent way to add heat and remove humidity and dampness from any bathroom.

Available in three sizes, the NB style towel warmers are finished in a high quality white enamel for use in damp environments like bathrooms. They should not be installed in showers or areas where they are exposed to direct water spraying.

The NB style is perfect for minimal space requirements with a total depth of 5" and a width of 24". It is available in heights of 32", 48" and 72". These ready-to install towel warmers offer outputs from 2,000 BTU/Hr to 4,500 BTU/Hr at an average water temperature of 176°F (80°C).

All Buderus towel warmers have the water connections on the bottom and a manual air vent at the top. Mounting hardware is included. Piping accessories, valves and thermostatic heads are available as accessories.

i Buderus towel warmers must not be used with potable water or open loop systems.

Chapter 5 has detailed radiator output ratings in table and graphical form.

Model 22		Table 2		
Dimensions H x L x W	Dry weight		Water volume	
	lbs	kg	gal	liters
12"x16"x4"	16	7	0.4	1.7
12"x24"x4"	24	11	0.7	2.6
12"x36"x4"	36	16	1.0	3.8
12"x48"x4"	48	22	1.3	5.1
12"x63"x4"	63	28	1.8	6.7
12"x71"x4"	71	32	2.0	7.6
20"x16"x4"	27	12	0.7	2.6
20"x24"x4"	41	19	1.0	3.8
20"x36"x4"	62	28	1.5	5.8
20"x48"x4"	82	37	2.0	7.7
20"x59"x4"	101	46	2.5	9.4
20"x63"x4"	108	49	2.6	10.1
20"x71"x4"	121	121	3.0	11.4
24"x16"x4"	33	15	0.8	3.0
24"x24"x4"	49	22	1.2	4.5
24"x36"x4"	74	34	1.7	6.7
24"x48"x4"	98	45	2.3	8.9
24"x59"x4"	121	55	2.9	10.9
24"x63"x4"	129	59	3.1	11.7
24"x71"x4"	146	66	3.4	13.2
36"x16"x4"	48	22	1.1	4.2

Radiator Accessories

Buderus offers a variety of accessories for installation and control of the radiators for different piping arrangements.

Mounting Brackets

Buderus panel radiators include wall mounting brackets. Floor mounting brackets are available as an accessory.

Rough in instructions and mounting guidelines are presented in chapter 5.

Piping Connections

Each stocking radiator has 20 mm (approx. 3/4) metric male tapings on the bottom on one side. The radiator can be mounted with these connections facing left or right. Figure 9 shows supply and return connections which cannot be reversed. Buderus supplies the following compression fittings for most applications.

Compression fittings are available from Buderus in sets of two (see Table 3). These fittings are normally secured to the piping connection on the radiator. When diverter or shutoff valves are used, the compression fittings mount on the valve.

<i>Pipe size and style</i>	<i>Part #</i>
1/2" copper	6198924
12 x 2 mm (3/8" PEX)	1016870
16 x 2 mm (1/2" PEX)	1016874
20 x 2 mm (3/4" PEX)	1016879
5/8" copper	1646851

Additional accessories are available that help with the installation of the panel radiator as well as the application in which it is installed.

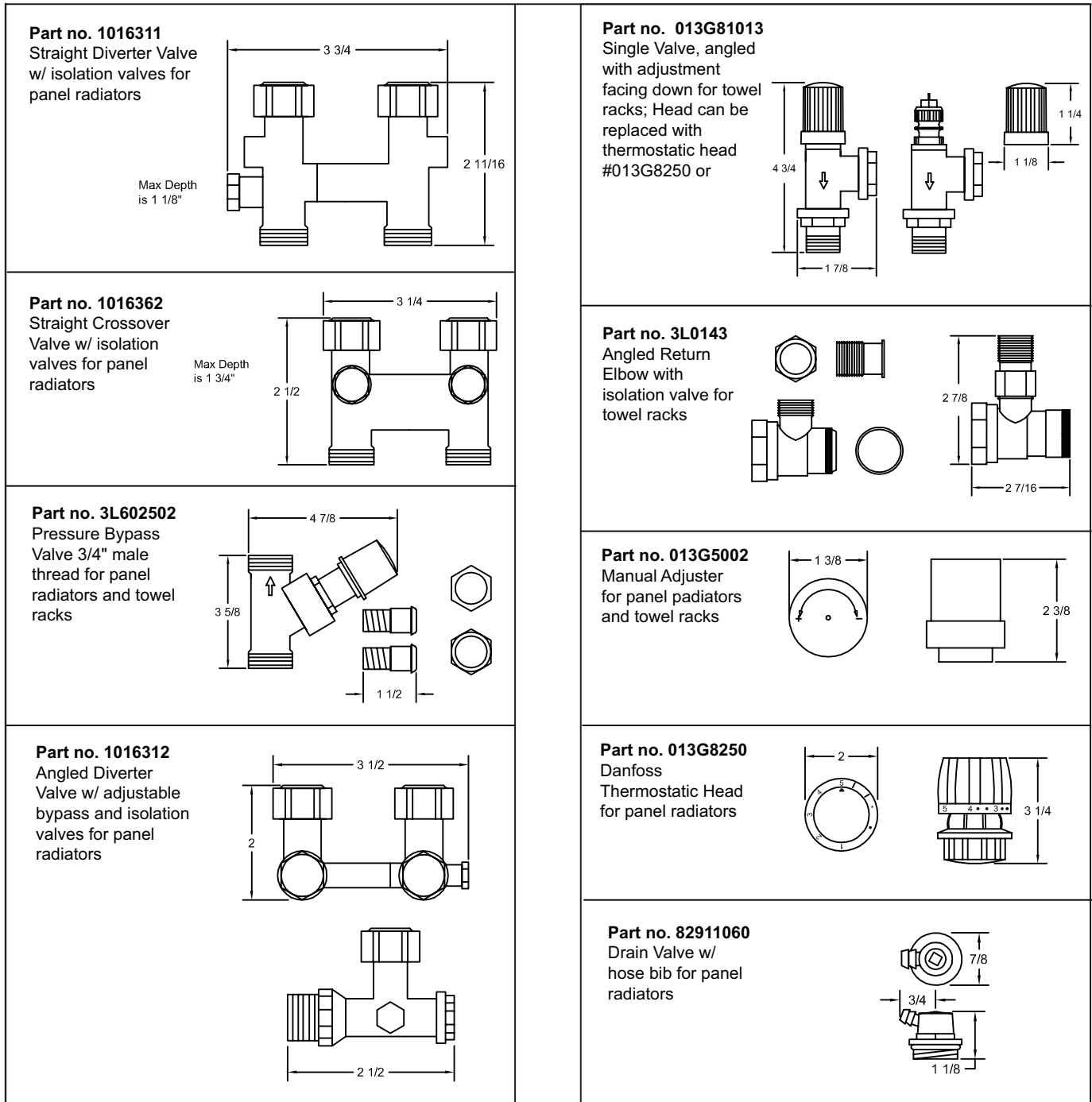

Fig. 1 Valve/accessory dimensions in inches

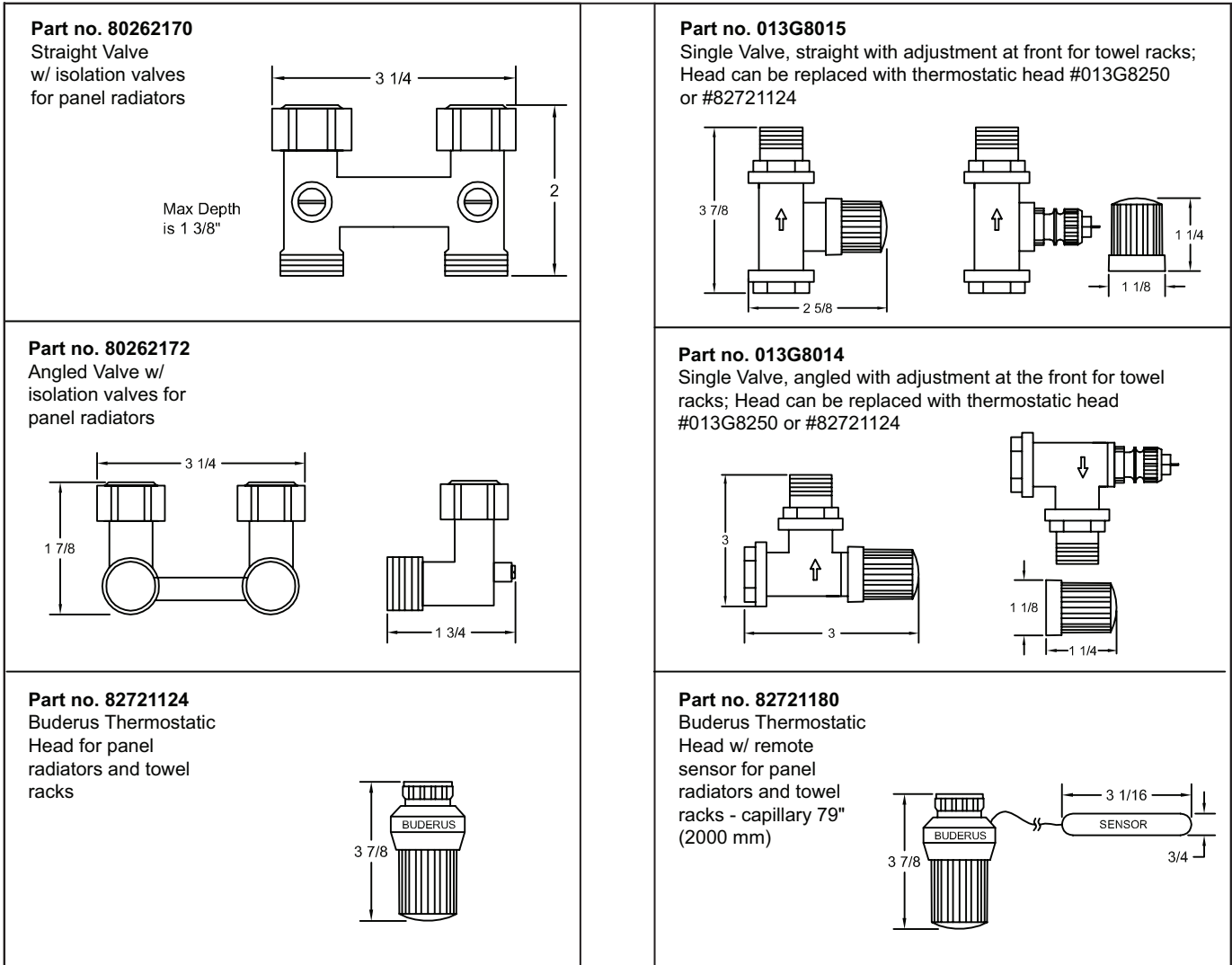

Fig. 2 Valve/accessory dimensions in inches continued

Floor Brackets for panel radiators		Table 4
Floor Brackets	Part Number	
Model numbers: 22	817-BUD	
Model numbers: 21	817-BUD-1	
Optional covers for brackets	81606400	

Flow Setter Valve:

Each radiator is equipped with a flow setter valve mounted on the same side as the water connections of the panel radiator. This valve consists of two part integral components for temperature control and flow balancing.

Flow Balancing:

Flow balancing is done by adjustment of the ring marked 1-7 and N on the flow setter valve, lining the desired setting up with the dimple in the first ring. Turning of the ring adjusts the diameter available for water flow. The N marking indicates a fully open setting; the 1 marking indicates nearly full restriction. The diagram on page 13 shows the pressure drop across the radiator as a function of the flow rate and setting of the flow setter.

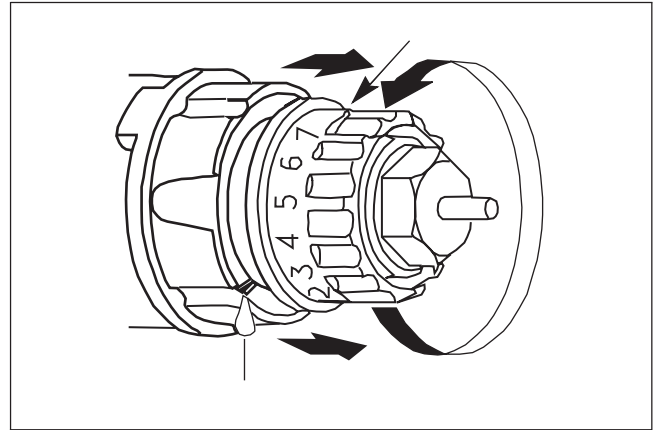

Fig. 3 Flow setter valve adjustment

Air Vent and Drain Plug

Each radiator is equipped with a manual air vent (1/2") and removable drain plug (3/4") for draining the radiator. A flat head screw driver is needed to open the air vent.

Diverter Valves:

Straight (part number 1016311) and angled (part number 1016312) diverter valves are available from Buderus for use in a one-pipe system (fig. 4). Shut offs are located on the supply and return branches to the radiator, allowing to isolate the radiator from the piping system so it can be drained and removed without decommissioning the complete heating system.

Each diverter valve is factory set for 35 % flow through the radiator and 65% through the bypass. Other flow percentages are easily set according to the diagram (fig. 5). To adjust the bypass, turn the spindle clockwise to the fully closed position. Then open the bypass spindle the desired number of turns from the fully closed position. Refer to the chart that is on page 30, explaining the pressure drop for a one-pipe system with diverter valves. You will need to add up the pressure drop of radiator and diverter valve when sizing the circulator.

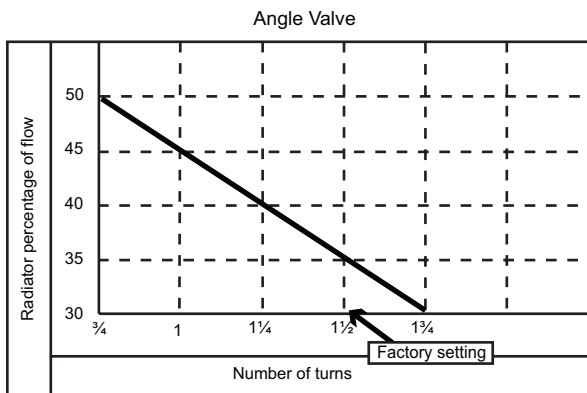
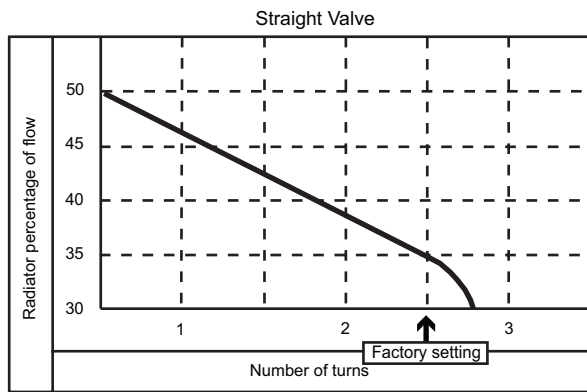

Fig. 5 Setting for Straight and Angled diverter valves

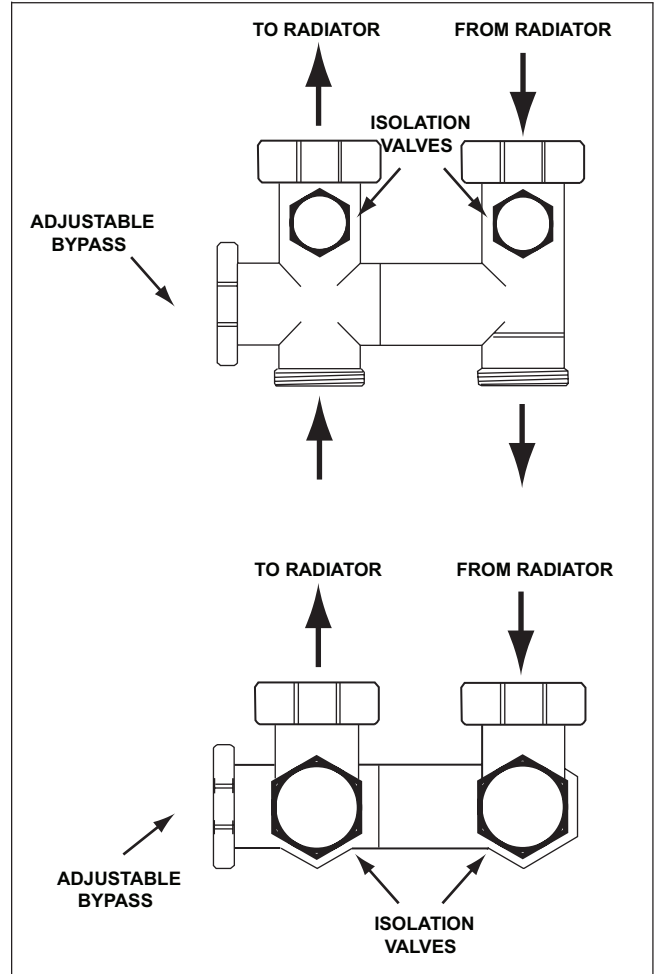

Fig. 4 Straight and Angled Diverter Valves

Installation considerations:

1. The valve mounts directly to the supply and return of the radiator. The compression fittings now connect to the diverter valve.
2. Allow 5" floor clearance below the radiator for the straight; 4" for the angled diverter valve.

Thermostatic Sensor head:

Adding a Buderus Thermostatic Head enables room-by-room zone control for optimum comfort and efficiency. It is easily installed on the flow setter valve.

A thermostatic head with remote sensor is available for locations where the valve head would be covered behind a curtain or otherwise blocked from sensing the actual room temperature. Length of the capillary: 79" (2000 mm).

Temperature Control:

Thermostatic control head is mounted on the flow setter valve of panel radiators and towel racks, and through its capillary expansion controls the flow rate and therefore the heat output of the panel. When using the thermostatic head the flow setter valve needs to be in the N position. A moveable, spring-loaded seat assembly inside the flow setter valve regulates the water flow through thermostatic action of the control head. This thermostatic head is required for individual temperature control at each radiator. The asterics provides frost protection of the panel itself provided the heating system is operational. The sensor indicator numbers correspond to the following approximate temperatures:

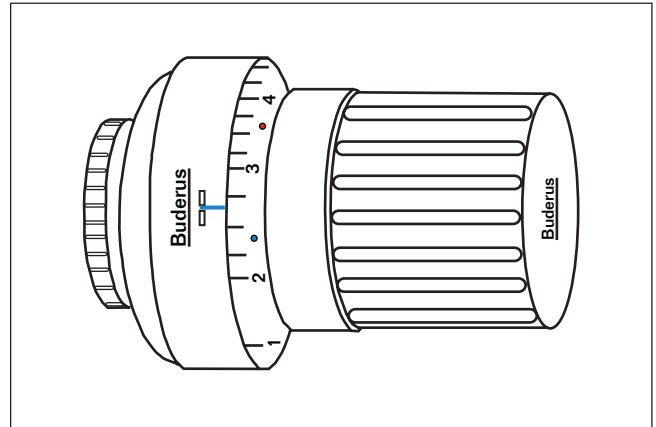

Fig. 6 Thermostatic Sensor Head

Thermostatic Sensor Head Setting		Table 5				
Dial	*	1	2	3	4	5
Room Temperature °F	40	57	63	68	73	79
Room Temperature °C	5	14	17	20	23	26

4. Mounting Guidelines

Panel Radiator Installation

Both model 21 and 22 radiators can be wall or floor mounted. All wall brackets must be secured to studs or other supports of sufficient strength for panel radiator weight. Radiators with a length of 71" or less require 2 brackets (1 set); lengths 79" or larger require 2 sets.

Note: Do not attempt to mount radiators solely to sheet rock or similar material.

Radiator Clearance Requirements:

Clearance for right hand radiators		Table 6
Clearance dimensions	Minimum clearance	Reason
Floor	2" (51mm)	- No diverter valves
	4" (102mm)	- Angled diverters
	5" (127mm)	- Straight diverters
	5" (127mm)	- Cross-over valves
Side of flowsetter valve	5" (127mm)	Thermostatic Sensor Head
Side opposing the flowsetter valve	2" - 4" (51-102mm)	Access to manual air bleeder
Top	2" - 4" (51-102mm)	Access to the top of wall bracket

Model 21 and 22: Wall Mounting

Each bracket is supplied with a slotted plastic locating clip. Position brackets evenly along the radiator and at least 4" in from either side for aesthetic reasons. The bottom of the radiator rests 5/8" above the bottom edge of the bracket. The radiator wall clearance can be set at 1-9/16" or 2-1/16" depending on the orientation of the plastic locating clips. Piping connections are located at 1-3/16" return and 3-3/16" (supply) in from the valve side of the radiator. The piping wall offset is 3-9/16" or 4-1/16" for both Model 21 and 22 radiators. For left hand radiators, measure these dimensions from the left side. See Fig. 8 and 9 for details.

Mount the brackets to studs or other wall supports capable of carrying the load of the full radiator (see Tables 1 & 2). Use at least 2 screws per bracket. Pull the T-shaped plastic securing plate forward and slide the top holder upward.

Insert the radiator with the bottom edge into the locating clip at the bottom of the bracket. Now slide the top bracket down to secure the radiator in place. Refer to the installation instructions included with the brackets for details.

Model 21 and 22: Floor Mounting

Floor brackets permit placement of Model 21 and 22 radiators in front of tall windows or where wall mounting is not an option. These brackets include a floor pedestal mount, radiator support, channel section and tightening assembly. The top grille of the radiator must be removed to install the channel section and tightening assembly. Radiators are adjustable in height from 4" to 8" bottom clearance.

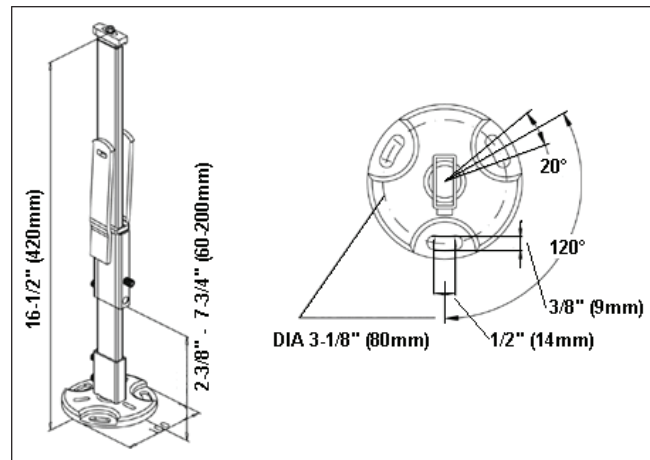

Fig. 7 Floor mounting bracket

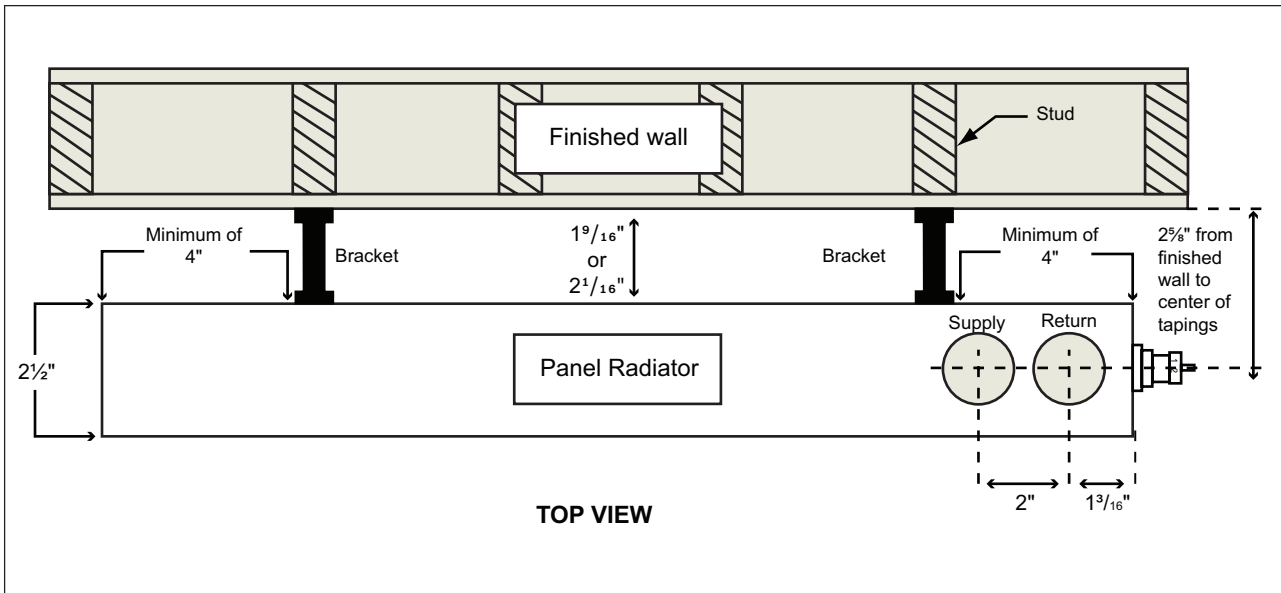

Fig. 8 Model 21 Panel Radiator Rough in Dimensions in inches for wall mounting

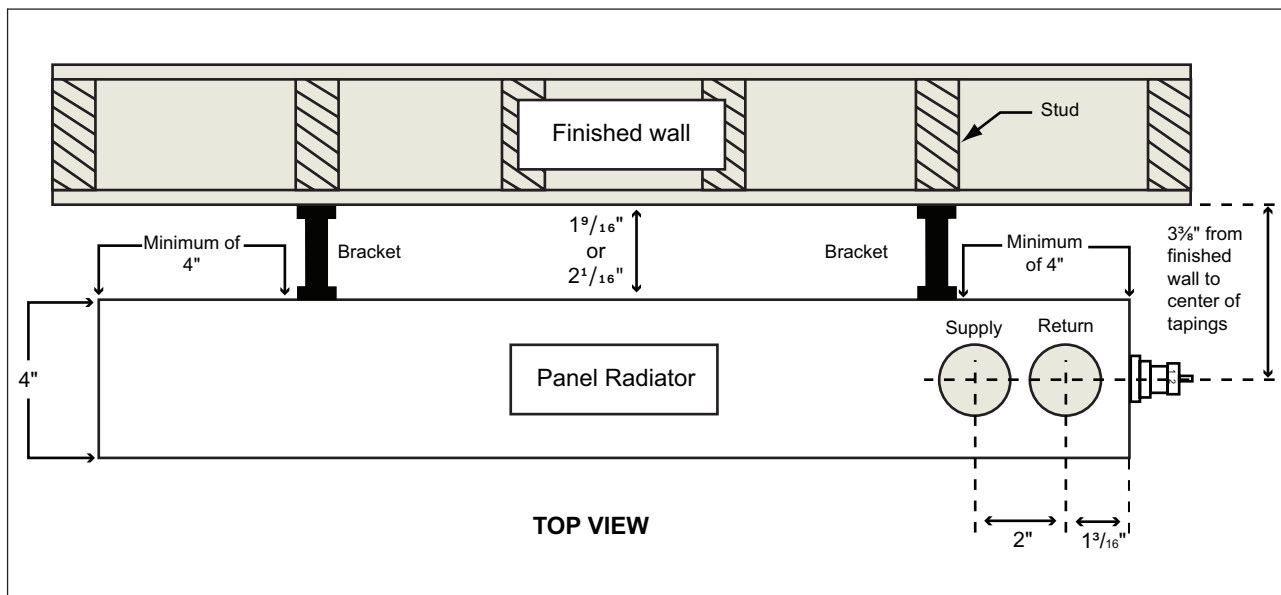

Fig. 9 Model 22 Panel Radiator Rough in Dimensions in inches for wall mounting

5. Radiator Output Ratings

Outputs depend on panel radiator size, average water temperature, and room temperature.

Four examples are presented below to illustrate a range of options. If none of them applies, use Figure 10 and Table 9 to determine output based on individual requirements.

Tables 7 and 8 show the outputs of Model 21 and 22 in-stock radiators at four different water temperatures. Use the high temperature column if restricted in wall space. To maximize efficiency in condensing boiler applications, ensure the return water temperature drops below the flue gas' dew point of 131°F (55°C) for significant periods of the heating season.

2½

Radiator outputs in BTU/Hr:

Model 21: 2½" (63.5mm) deep					Table 7
	Output BTU/hr				
Supply	194°F (90°C)	176°F (80°C)	158°F (70°C)	140°F (60°C)	Part Number
Delta T	36°F (20°C)	36°F (20°C)	18°F (10°C)	18°F (10°C)	
12"x24"x2½"	1900	1500	1300	1000	3-41224
12"x36"x2½"	2900	2300	2000	1400	3-41236
12"x48"x2½"	3800	3000	2600	1900	3-41248
12"x59"x2½"	4700	3700	3200	2300	3-41259
12"x71"x2½"	5700	4500	4000	2900	3-41271
20"x24"x2½"	2800	2200	1900	1400	3-42024
20"x36"x2½"	4200	3300	2900	2100	3-42036
20"x48"x2½"	5600	4400	3900	2800	3-42048
20"x59"x2½"	7000	5500	4800	3500	3-42059
20"x71"x2½"	8400	6600	5800	4200	3-42071
24"x24"x2½"	3200	2500	2200	1600	3-42424
24"x36"x2½"	4900	3800	3400	2400	3-42436
24"x48"x2½"	6500	5100	4500	3200	3-42448
24"x59"x2½"	8100	6300	5600	4000	3-42459
24"x63"x2½"	8700	6800	6000	4300	
24"x71"x2½"	9700	7600	6700	4800	3-42471

All values based on 68°F (20°C) room temperature.

Model 22: 4" (100mm) deep					Table 8
	Output BTU/hr				
Supply	194°F (90°C)	176°F (80°C)	158°F (70°C)	140°F (60°C)	Part Number
Delta T	36°F (20°C)	36°F (20°C)	18°F (10°C)	18°F (10°C)	
12"x16"x4"	1600	1300	1100	800	3-21216
12"x24"x4"	2400	1900	1700	1200	3-21224
12"x36"x4"	3700	2900	2500	1800	3-21236
12"x48"x4"	4900	3800	3400	2400	3-21248
12"x63"x4"	6500	5100	4500	3300	3-21263
12"x71"x4"	7300	5800	5100	3700	3-21271
20"x16"x4"	2500	2000	1700	1200	3-22016
20"x24"x4"	3700	2900	2600	1900	3-22024
20"x36"x4"	5600	4400	3900	2800	3-22036
20"x48"x4"	7500	5900	5200	3700	3-22048
20"x59"x4"	9300	7300	6400	4600	3-22059
20"x71"x4"	11200	8800	7800	5600	3-22071
24"x16"x4"	2900	2300	2000	1400	3-22416
24"x24"x4"	4300	3400	3000	2200	3-22424
24"x36"x4"	6500	5100	4500	3200	3-22436
24"x48"x4"	8700	6800	6000	4300	3-22448
24"x59"x4"	10800	8400	7400	5300	3-22459
24"x71"x4"	13000	10200	9000	6500	3-22471
36"x16"x4"	3500	2700	2400	1700	3-23616

All values based on 68°F (20°C) room temperature.

If tables 7 and 8 do not match a system's requirements, the following guidelines provide means to calculate the effects of ambient room temperature, supply water temperature and temperature drop through the radiator on the radiator output.

Ambient room temperature effect: The (adjusted) output of a radiator at any room temperature (ΔT_{room}) can be computed from the output listed at a room temperature of 68°F (20°C) as:

Adjusted Output = Listed Output x $[1 + \alpha \times (68 - T_{\text{room}})]$
(T_{room} in °F) where α is a correction factor computed as:
 $\alpha = 1.385 / (\Delta T_{\text{supply}} - 75)$ with ΔT_{supply} in °F.

Note: The listed radiator output depends on the supply temperature.

Example: Select the proper radiator to heat a porch which is to be kept at 55°F (13°C) during the winter. Maximum heat loss is 8,750 Btu/hr. Assume supply temperature equal to 194°F (90°C).

Solution: The larger temperature difference between the radiator and the porch increases the radiator output. To find the proper size radiator, we must compute the listed output at 68°F (20°C).
Adjusted Output = 8,750 Btu/hr at 194°F (90°C) and 55°F (13°C). (ΔT_{room}).

Compute correction factor α as:
 $\alpha = 1.385 / (194 - 75) = 0.0116$
Listed Output = $8,750 / [1 + (0.0116 \times (68 - 55))] = 7,560$ Btu/hr
From Table 8: Use Model 22 20" x 48" x 4" instead of Model 22 24" x 48" x 4" (listed output = 7,500 Btu/hr).

This ambient room temperature effect is generally small and need only be considered in system design if desired room temperatures are well beyond the typical 68 - 72°F (20 - 22°C) range.

Supply water temperature effect: The effect of different supply temperatures on the output of panel radiators is computed using the conversion factors of Table 9 or read directly from the Performance Curves in Figure 10.

Table 9 contains conversion factors needed to compute the adjusted radiator output from the listed ratings. The ΔT factor is computed as the difference between the average water temperature and room temperature.

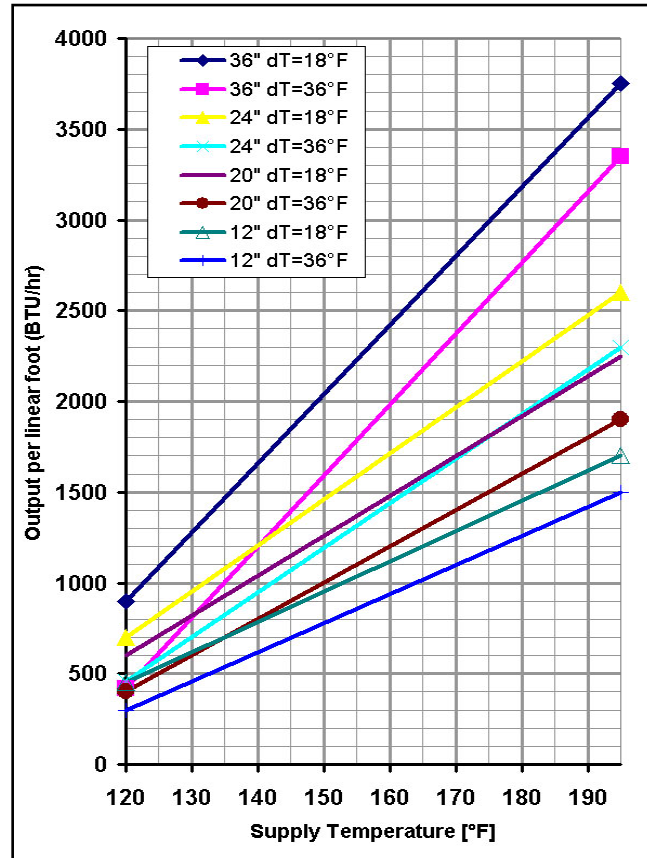

Fig. 10 Performance Curves Model 22 Radiators

Conversion Factors		Table 9
ΔT in °F (°C)		Conversion Factor
10 (6)		0.045
20 (11)		0.112
30 (17)		0.198
40 (22)		0.275
50 (28)		0.367
60 (33)		0.466
70 (39)		0.569
80 (44)		0.677
90 (50)		0.789
100 (56)		0.905
108 (60)		1.000
110 (61)		1.024
120 (67)		1.147
130 (72)		1.272
140 (78)		1.401
150 (83)		1.535

Example: Compute the output of a Model 21 20" x 59" radiator with an average water temperature of 140°F (60°C) in the radiator and a room temperature of 70°F (21°C).

Solution: Listed output = 7,000 Btu/hr (See Table 9)
 $\Delta T = 140 - 70 = 70^\circ\text{F}$: Conversion Factor = 0.569 (See Table 9) Adjusted output = $0.569 \times 7,000 = 3,983$ Btu/hr.

Comment: The effect of the ambient room temperature is already accounted for in the conversion factors listed in Table 9. Figure 10 contains the performance curves for Model 22 radiators showing the output per linear foot of radiation for the different heights as a function of supply temperature.

Different curves are shown based on a 18°F (10°C) and 36°F (20°C) temperature drop through the radiator and a 68°F (20°C) room temperature.

Example: A room requires 12,000 Btu/hr with 6 ft of available space. Maximum supply temperature is 170°F (77°C). What model(s) can be used for this application?

Solution: Required heat output per foot = $12,000/6 = 2,000$ Btu/hr per linear foot. Check Figure 10 at 170°F (77°C) supply temperature and 2,000 Btu/hr Output:

Model 22: Use 24" high with about 18°F (10°C) ΔT drop.

6. Radiator Selection Procedure

Several factors must be considered in the selection of a panel radiator. These are:

- Heat loss of the room.
- Location of the radiator(s) and available floor to window height.
- Desired piping arrangement.
- Room usage.
- Type of room control used.

All factors are discussed below and must be given consideration prior to final radiator size and model selection.

1. The panel radiator(s) must have at least the required capacity to match the heat loss. Oversizing is not a problem provided thermostatic sensor heads or other temperature sensitive controls are used to cycle the heat off once the desired room temperature is reached.

2. Radiators are frequently selected based on the intended location. A 3' radiator fits nicely under a 36" window, whereas a 24" radiator may only be needed based on the heat loss. Window size and number of windows as well as overall room size affect the selection process. Once a room exceeds 12' x 12', it is advisable to install 2 smaller radiators on outside walls for more comfort.

3. The selected piping arrangement affects the radiator sizing on monoflow or one-pipe diverter valve based systems, because the supply temperature reduces with distance from the boiler. Minor oversizing of the last radiators in the one-pipe system may be necessary.

4. For rooms that are used occasionally where a rapid heat-up is required, it is advisable to install some extra radiation. This becomes important on heating systems operating with outdoor reset control. There is no need for over sizing radiation in main living areas as they are generally maintained at uniform temperatures.

5. Radiators equipped with thermostatic sensor heads on a constant circulation system maintain a more uniform room temperature and respond faster to temperature disturbances such as open doors or windows, solar or internal heat gain from appliances, lights, etc. compared to a centrally located thermostat system.

7. Piping Arrangements

The design of a panel radiator based heating system involves selection of a piping system, pipe sizes, overall design temperature drop, required flow rates and desired type of system control. For trouble-free system operation, do not exceed the flow rates in Table 10.

Pipe size*	Max flow (gpm)	Q ($\Delta T=20^{\circ}F$)	Q ($\Delta T=30^{\circ}F$)	Q ($\Delta T=40^{\circ}F$)
1/2" copper or PEX	1.5	15,000	22,500	30,000
5/8" PEX	2.0	20,000	30,000	40,000
3/4" copper	4.0	40,000	60,000	80,000
1" copper	8.0	80,000	120,000	160,000
1 1/4" copper	14.0	140,000	210,000	280,000
Diverter valve	2.0	20,000	30,000	40,000
Radiator Flow	2.5	25,000	37,500	50,000

Note: Q ($\Delta T = 20^{\circ}F$ ($11^{\circ}C$)) denotes the maximum heat load carrying capacity based on a $20^{\circ}F$ ($11^{\circ}C$) temperature drop.

*Pipe size used for main supply/return piping in multiple one-pipe diverter valve based systems or for one-pipe systems using monoflow tees. This information is useful for pipe sizing in two-pipe distribution systems.

This chapter discusses several piping arrangements, guidelines for system design, pipe size, pump selection and fine-tuning of individual components. Heat loss (Q), water flow rate (GPM) and temperature drop (ΔT) through a hydronic heating system are related to each other as:

$$Q = 500 \times GPM \times \Delta T$$

This equation is used extensively for accurate sizing of radiators.

One-Pipe System Options

Figure 11 presents three different one-pipe arrangements. In any one-pipe system, a single pipe connects all radiators together. Fewer materials are needed in a one-pipe system where a perimeter loop supplies water to all radiators. Since water may flow through all radiators and cools off along the way, it is necessary to oversize the last radiator(s) in the loop. A sizing procedure is outlined.

Table 10 shows maximum Btu load on a one-pipe system based on pipe size and overall temperature drop.

Series loop system

All water flows through all radiators.

A thermostatic head cannot be used on any radiator as it will shut off all flow. A central thermostat is required for temperature control. Do not exceed heat loads as listed in Table 10.

Option 1: one-pipe system with monoflow tees (Fig 11).

Monoflow tees are used to divert some water from the main loop into each radiator. Use one monoflow tee on the return if the radiator(s) are located above the main loop; use two monoflow tees if the radiators are installed below the main loop. Place the tees in the main loop to each radiator at least 12" apart. Thermostatic heads on each radiator provide very easy means for individual temperature control. The system can be operated off a central thermostat or with constant circulation using an outdoor reset system. Size the main loop based on the selected temperature drop ($20^{\circ}F$, $30^{\circ}F$, or $40^{\circ}F$ ($11^{\circ}C$, $17^{\circ}C$, $22^{\circ}C$)) and heat load. Make sure to oversize the last radiators properly, especially when using an overall temperature drop of $30^{\circ}F$ ($17^{\circ}C$) or $40^{\circ}F$ ($22^{\circ}C$). It is important to size the main supply and return pipes for the total heat load and volume to avoid flow restriction or noise.

Option 2: one-pipe system with diverter valves (Fig 12).

This arrangement is similar to using monoflow tees except that now each radiator is equipped with a diverter valve. Secondly, the total loop flow can NOT exceed 2 GPM because of possible noise at greater flow rates. The bypass adjustment in the diverter valve can be used to throttle down the flow through the first radiators and increase flow through the last radiators in the loop to make up for the drop in loop temperature. Thermostatic heads on each radiator provide an easy means for individual temperature control. The system can operate off a central thermostat or with constant circulation using an outdoor reset system. Follow Table 10 for pipe sizing. It is important to size the main supply and return pipes for the total heat load and volume to avoid flow restriction or noise.

Option 3: Multiple one-pipe systems.

Options 2 and 3 above can be installed in a multiple loop fashion where several one-pipe systems are connected between a common supply and return manifold. Assure adequate flow in all piping systems when using monoflow loops and/or diverter valve loops. Isolation and balancing valves are recommended on each loop for service and flow control.

A properly sized pump operating on constant circulation can supply water to all loops. A single Grundfos UP15-42 or equivalent can handle up to 3 diverter valve loops; use a Grundfos UP26-64 or equivalent for 4 to 6 loops. Size the main piping for the combined flow in all branches,

following the guidelines in Table 10. Refer to the Pressure Drop Curves (Fig. 14 & 15) on pages 30 & 31 for estimating the pressure drop through each radiator when using monoflow tees. Use the Pressure Drop Diagram on page 30 for a one-pipe system with diverter valves. Use the approximate flow rate through the radiator and flow setter valve setting to read off the pressure drop. Size the circulator based on total flow and overall system pressure drop. Thermostatic heads are required in this arrangement for individual temperature control.



Ensure all supply and return piping is sized properly to avoid restriction and noise.

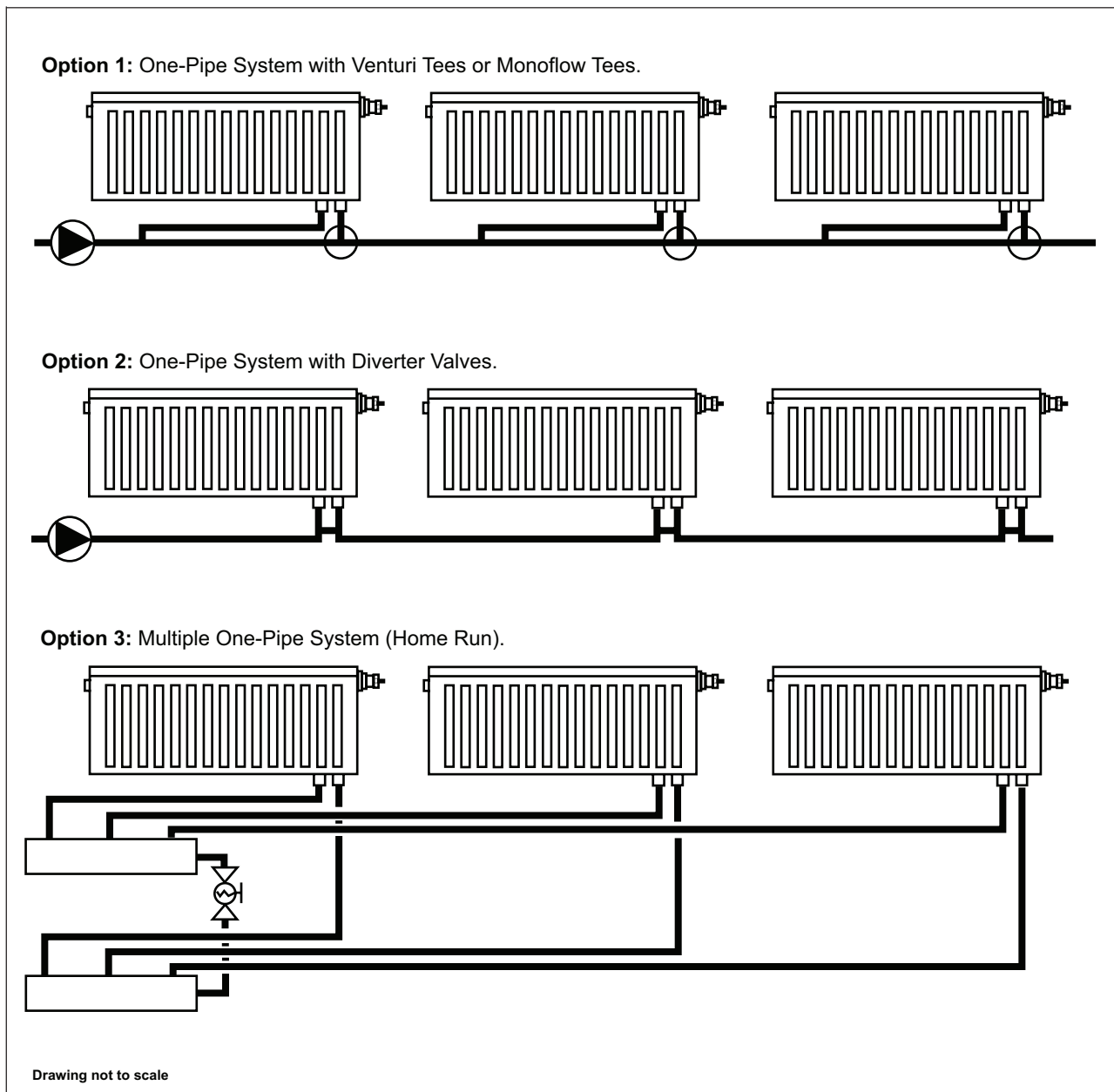

Fig. 11 One-Pipe System Options

Design procedure for One-Pipe System with monoflow tees or diverter valves

1. Select radiator hook-up sequence.
2. Determine individual heat loads.
3. Determine linear footage of wall space available for each radiator.
4. Compute the required heat load per foot for each room.
5. Select system temperature drop $\Delta T = 20, 30$ or 40°F ($11^{\circ}\text{C}, 17^{\circ}\text{C}, 22^{\circ}\text{C}$) and maximum supply temperature.
6. Compute the total heat load (Q) in the loop by adding the individual heat loads.
7. Determine loop flow rate from total heat load (Q) and selected ΔT as: $\text{GPM (loop)} = Q / 500 / \Delta T$
8. Compute the supply temperature for each room based on the supply temperature and heat load of the previous room and the total loop flow rate (GPM) as:

New Supply Temp = Previous Supply Temp - (Q room) / 500 / GPM

With the supply temperature computed in Step 8 and the linear heat load in Step 4, refer to Figure 10 to find the required radiator size, or tables 9 and 10 for the total individual radiator output if the any of the four examples applies. Use the same ΔT value in reading from the curves in Figure 10 as the selected value in Step 5. In case more than one radiator is to be installed in a room, size all radiators based on the above procedure.

Table 11

1	Select room sequence	Room 1	Room 2	Room 3	Room 4
2	Heat load per room				
3	(BTU/hr)				
4	Available wall space (ft)				
5	Minimum Required Heat Load per linear ft (BTU/ft)	$\Delta T = \text{___}^{\circ}\text{F}$ Supply temp(room1) =max supply temp = $\text{___}^{\circ}\text{F}$			
6	Total heat load (BTU/ft)	$Q = \text{___}$ BTU/Hr			
7	Total loop GPM	$\text{GPM(loop)} = Q / 500 / \Delta T = \text{___}$ GPM			
8	Supply temp per room	$\text{___}^{\circ}\text{F}$	$\text{___}^{\circ}\text{F}$	$\text{___}^{\circ}\text{F}$	$\text{___}^{\circ}\text{F}$
9	List possible radiator Models and sizes				

Example: One-Pipe System Layout

Design a one-pipe system for a second floor with individual room temperature control:

Description	Heat Load	Window Size	Hook-up Sequence
Bathroom	3,000	1x3 ft wide	first
Master Bedroom	9,000	2x4 ft wide	second
Bedroom 2	6,000	1x3 ft wide	third
Bedroom 3	4,000	1x3 ft wide	fourth

Solution:

Step 1. Complete the Radiator Sizing Sheet to find minimum size radiator.

Step 2. Select control strategy and size piping and pump using Table 7.

Step 3-4: See Table 13.

Step 5: Assume temperature drop (ΔT) = 30°F (17°C), maximum supply temperature = 180°F (82°C).

Step 6: Add all heat loads from row 2 and enter in Step 6.

Step 7: Compute flow rate in the one-pipe system in GPM.

i The flow rate can not exceed 2 GPM when using diverter valves. Using a larger ΔT lowers the GPM.

Step 8: Here we must compute the supply temperature for each room. Start with the first room and compute each supply temperature step by step as shown here.

Supply Temp (1) = 180°F (82°C)

Supply Temp (2) = $180 - 3000 / (500 \times 1.47) = 176^\circ\text{F}$ (80°C)

Supply Temp (3) = $176 - 9000 / (500 \times 1.47) = 164^\circ\text{F}$ (70°C)

Supply Temp (4) = $164 - 6000 / (500 \times 1.47) = 156^\circ\text{F}$ (60°C)

Step 9: Now with each value computed in steps 4 and 8, locate those values in Fig. 10. The output curve located directly above that point identifies the minimum size radiator required. Use the 18°F (10°C) ΔT curves if designing for a 20 to 30°F (11 to 17°C) temperature drop, use the 36°F (20°C) ΔT curves if designing for a 40°F (22°C) drop.

Results: Output/ft Radiator Models

Bedroom Supply Temp = 180°F (82°C) 1500 Btu/ft #22 20"

M. Bedroom Supply Temp = 176°F (80°C) 1125 Btu/ft #22 x 12

Bedroom #2 Supply Temp = 164°F (70°C) 2000 Btu/ft #22 24"

Bedroom #3 Supply Temp = 156°F (60°C) 1333 Btu/ft #22 24"

Use 5/8" PEX and diverter valves (or: 3/4" copper main line with 3/4" x 3/4" x 1/2" monoflow tees) with thermostatic heads on all radiators for individual room control. Place a thermostat in the bathroom or master bedroom or run constant circulation. Use a Grundfos UP15-42, a Taco 007, or equivalent pump with a balancing valve to throttle the flow. Noise may otherwise develop in the diverter valves.

		Bathroom	Master Bedroom	Bedroom 2	Bedroom 3
1	Select room sequence				
2	Heat load per room	3000	9000	6000	4000
3	Available wall space (ft)	2	8	3	3
4	Minimum required heat load per linear foot (BTU/ft)	1500	1125	2000	1333
5	Minimum Required Heat Load per linear ft (BTU/ft)	$\Delta T = 30^\circ\text{F}$ Supply temperature (room1) = max supply temperature = 180 °F			
6	Total heat load (BTU/ft)	$Q = 3000 + 9000 + 6000 + 4000 = 22000 \text{ BTU/Hr}$			
7	Total loop GPM	$\text{GPM} = Q / 500 / \Delta T = 22000 / 500 / 30 = 1.5 \text{ GPM}$			
8	Supply temp per room	$\Delta T = Q / 500 / \text{GPM}$			
		180	176	164	156
9	Possible radiator Models and sizes				

Two-Pipe System Options

Figure 12 illustrates two common two-pipe configurations.

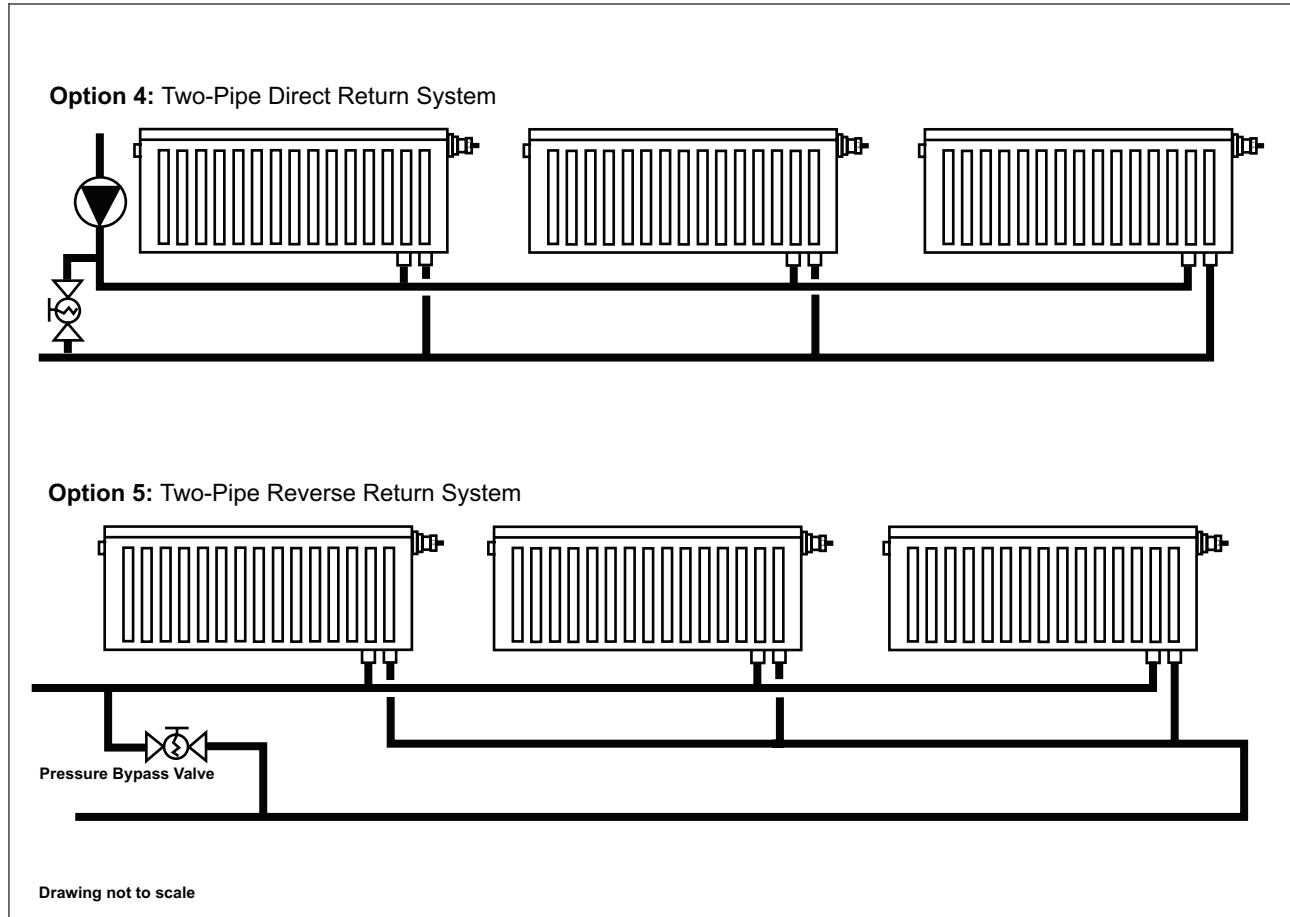

Fig. 12 Two-pipe System Options

Benefits of Two-Pipe Systems:

1. Each radiator is supplied with the same temperature water maximizing radiator output.
2. No limit to the number of radiators on a two pipe system loop; the supply and return mains must be sized for maximum flow. Follow the guidelines in Table 10 for sizing the supply and return runs. Use 1/2" copper or PEX tubing to connect radiators to main runs.
3. Individual radiator control is easily done using thermostatic sensor heads. Use constant circulation with outdoor reset control for optimum system performance. A central thermostat can be used for on/off control; however, thermostat location governs overall system control and may override individual room control.

Requirements for Two-Pipe System:

- Two main distribution pipes are needed; one for the supply to the radiators and a second pipe for the return to the boiler.
- A pressure actuated bypass valve (Part No. 3L602502 for a 3/4" Danfoss valve) connected between supply and return mains is necessary on constant circulation systems with thermostatically controlled radiators to prevent dead-heading the pump. This bypass valve is not needed on thermostat controlled systems if the radiators are not equipped with thermostatic sensor heads.

Design Procedure for Two-Pipe System

1. Determine individual heat loads.
2. Select desired overall temperature drop of systems (ΔT); i.e. 20°F (11°C), 30°F (17°C) or 40°F (22°C).
3. Compute loop flow rate GPM from:

$$\text{GPM} = Q / 500 / \Delta T$$
4. Use Figure 10 or the Conversion Factors in Table 9 to determine output of radiator models in case of lower supply temperatures.
5. Use the Pressure Drop Chart on pages 30-31 as a guide to set the flow setter valve for each radiator to ensure proper flow through each radiator. Adjust flow setter valves as needed based on system performance. Close down the flow setter on “hot” radiators by dialing in a lower setting on the adjustment ring, or adjust the flow setter to a higher setting for “cool” radiators.
6. Size piping based on system flow rate; size circulator based on flow rate and overall system pressure drop.

Table 14					
1	Select room sequence	Room 1	Room 2	Room 3	Room 4
2	Heat load per room				
3	(BTU/hr)				
4	Available wall space (ft)				
5	Minimum Required Heat Load per linear ft (BTU/ft)	$\Delta T = \text{___}^\circ\text{F}$ Supply temp(room1) =max supply temp= $\text{___}^\circ\text{F}$			
6	Total heat load (BTU/ft)	Q = ___ BTU/Hr			
7	Total loop GPM	$\text{GPM}(\text{loop}) = Q / (500 \times \Delta T) = \text{___}$ GPM			
8	Supply temp per room	$\text{___}^\circ\text{F}$	$\text{___}^\circ\text{F}$	$\text{___}^\circ\text{F}$	$\text{___}^\circ\text{F}$
9	List possible radiator Models and sizes				

Example 2: Two-pipe System Lay-out

Design and select a two pipe panel radiator system with the following requirements:

Table 15			
Description	Heat Load	Window Size	Required BTU/ft
Walk-in closet	2,000	none	
Bathroom	5,000	1x2 ft wide	2,500
Bedroom 1	8,000	2x3 ft wide	1,333
Bedroom 2	10,000	2x4 ft wide	1,250
Master Bedroom	12,000	2x4 ft wide	1,500

Total Load: 37,000 Btu/hr

System Parameters:

Maximum Supply Temperature: 194°F (90°C)

Thermostat in master bedroom for ON/OFF control.

Solution: Two-Pipe System Lay-out

1. If sufficient space is available for radiators, select radiators based on required heat output and desired style. Select radiators from Tables 9 & 10 since the system temperature is similar to those listed.

If the radiators must be sized for the available window space, determine the minimum needed model radiator based on the required Btu/ft for each room from Figure 10 with a 194°F (90°C) supply temperature. Use the same supply temperature for each radiator in a two-pipe system.

2. Select an overall temperature drop of 20°F (11°C).
3. Compute system flow rate as: $GPM = Q / 500 / \Delta T = 37000 / 500 / 20 = 3.7 \text{ GPM}$
4. Combine all information in tabular form as shown in Table 2.

Table 16: Radiator Option Determination Chart: Two-Pipe System

Table 16					
Description	Heat Load	BTU/ft	Selected Models	No. and length of radiators	Flow-setter valve
Walk-in closet	2000			1	3-4
Bathroom	5000	2,500	1x #22 20"x36"	1x 3ft	6-7
Bedroom 1	8000	1,333	2x #22 12"x36"	2x 3ft	5-6
Bedroom 2	10000	1,250	2x #22 12"x48"	2x 4ft	6-7
Master Bedroom	12000	1,500	2x #22 20"x48"	2x 4ft	7-N

Balancing the system



Initial settings of flow setter valves will help to ensure proper flow through all radiators. Keep in mind that this is only a starting point and that the system may require further adjustment based on the heating characteristics of the structure.

Procedure for setting the flow-setter valves.

1. Identify the largest radiator. In the above example it would be the master bedroom radiator. The setting for this radiator should be "N". This radiator will have the highest pressure drop and requires that the flow-setter valve be fully open.
2. Using the Pressure Drop Chart on page 30-31, find the output for this radiator (at selected ΔT) at the bottom of the chart. Based on 6,000 btu/hr at a 20°F ΔT the flow rate for this radiator is 0.6 GPM. Follow the 0.6 GPM line vertically until you intersect the N setting. Reading across to the left you will see that the pressure drop for this radiator is approximately 12 in. W.C. or 1ft/hd.
3. Draw a horizontal line across the diagram at 12 in. W.C.
4. Select the next radiator. Identify its btu/hr output, locate this figure at the bottom of the chart as you did for the first radiator. At the corresponding flow-rate, move vertically on chart until you intersect the horizontal line that you drew indicating 12" W.C. Find the appropriate flow setting. If the value is between two settings, say 3 and 4, then simply set the valve between 3 and 4.
5. Repeat step 4 for remaining radiators.
6. Use guidelines in Table 10 to size main piping. In this case, use 3/4" copper mains with 1/2" copper (or PEX) to/from each radiator. Install a thermostat in master bedroom. Size circulator based on total flow rate and install balancing valve for flow control.

Piping Lay-out Suggestions:

1. For small systems, use one-pipe system with monoflow tees or diverter valves.

Btu's per loop:

15,000 - 20,000 Btu/hr with 1/2 " copper

20,000 - 30,000 Btu/hr with 5/8 " PEX.

Increasing the overall temperature drop in the system from 20°F (11°C) to 30°F (17°C) or 40°F (22°C) permits more radiation per loop. (See Table 14).

Oversize radiators by 20 - 30% at the end of a one-pipe loop. Always install a balancing valve in each loop to regulate the flow rate to eliminate possible flow noise.

Maximum flow rate for diverter valves: 2 GPM

Maximum flow rate per radiator: 2.5 GPM.

2. For larger systems, use two-pipe reverse return or multiple one-pipe systems with common supply and return manifolds. Refer to Table 10 for pipe sizing.
Pump Selection:
1-3 loops: Grundfos UP15-42, Taco 007 or equivalent
3-6 loops: Grundfos 26-64 or equivalent
Use pressure bypass valve on two-pipe systems to prevent deadheading the pump.

Radiator Selection & System Start-up Suggestions:

1. Size radiators based on heat load, location, available space, desired style and system operating temperatures.
2. Use of thermostatic sensor heads increases comfort, eliminates problems with over sizing the radiation and provides individual room control.
3. Balance the system to ensure proper heat output from each radiator using the flow setter valve on each radiator. Shut off thermostatic heads one at a time and monitor system response. Make necessary adjustments.
4. Retighten compression fittings slightly after initial start-up.

Pressure drop curves:

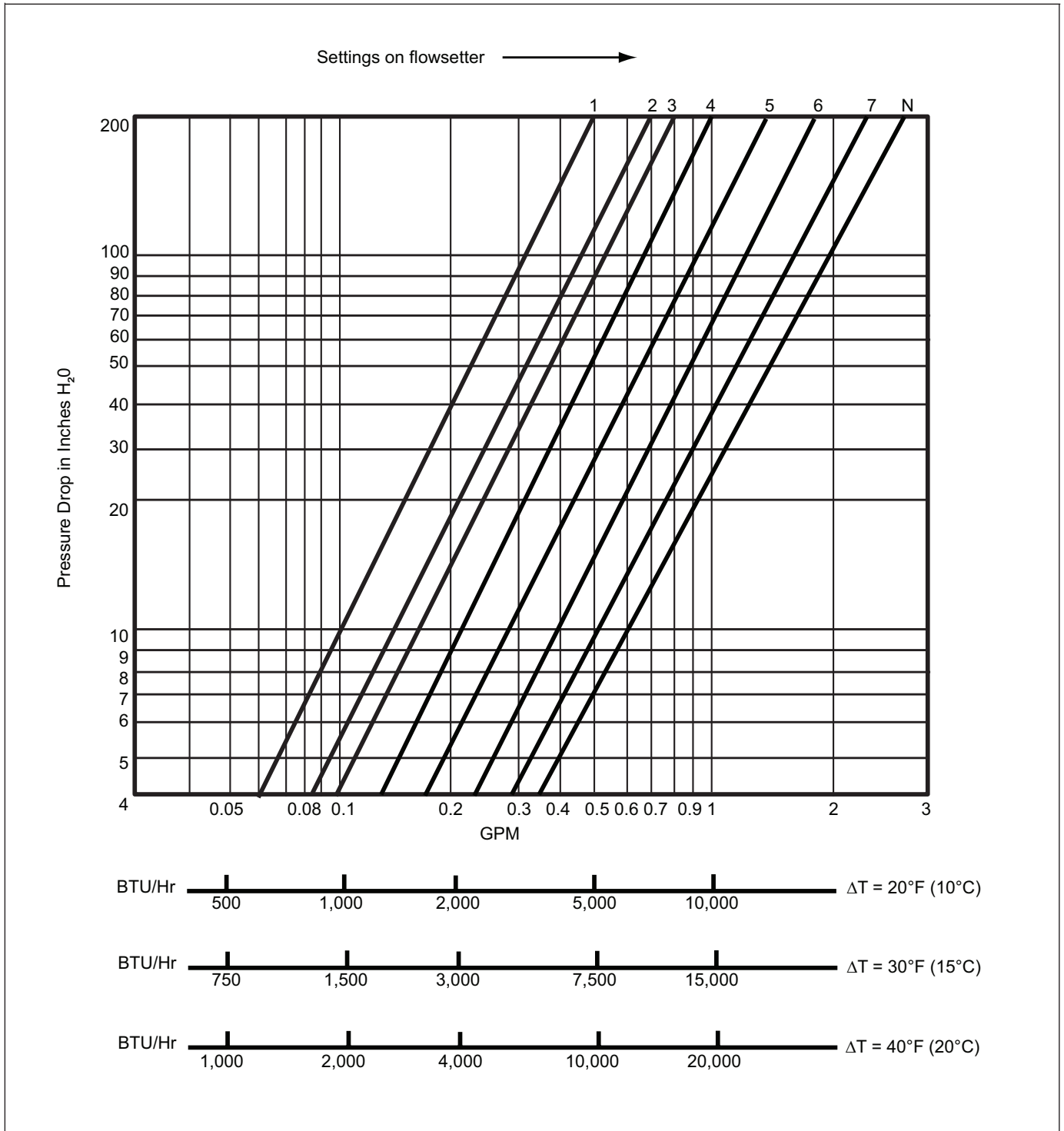

Fig. 13

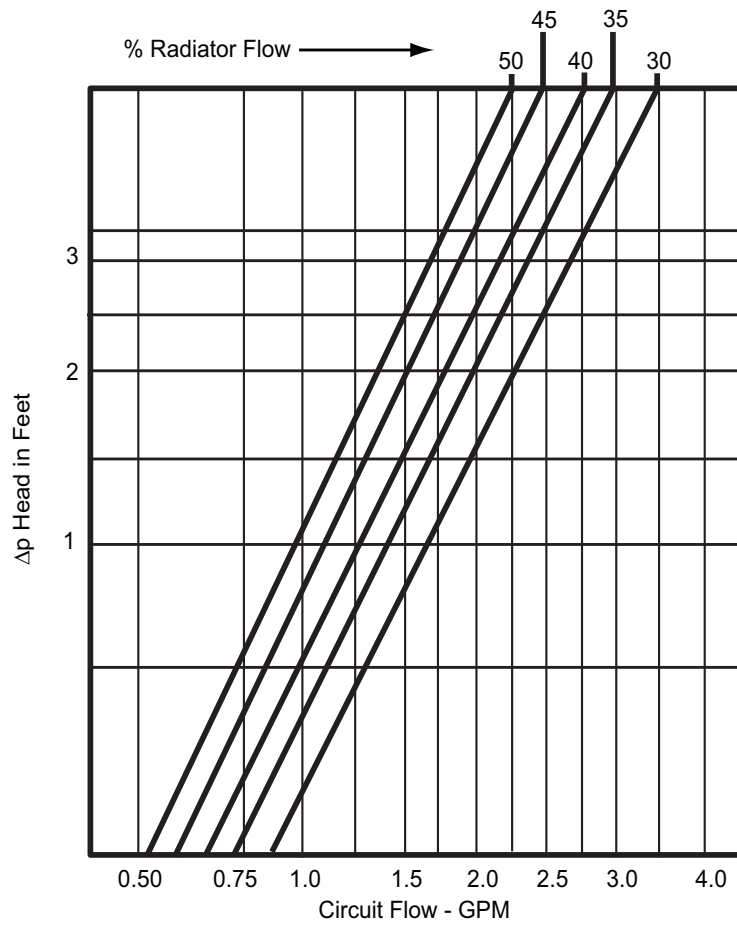

Fig. 14

8. Buderus NB Style Towel Racks

The Noblesse style towel racks are attractively designed with a vertical frame of two 2-3/4" round pipes connected horizontally with 1" curved round steel tubing precision welded in the interior. Two 1/2" NPT female tapings are available on the bottom of the towel rack for the supply and return. An air vent is already installed on the top right of the NB towel rack. The NB has an adjustable offset of 3" and 4" from the wall.

All towel racks come in a multi-layered, powder coat enamel white finish that is durable, easy to clean and ideal for most existing color schemes. Supply and return pipes are reversible. Openings in the towel rack are provided to hang towels. Complete wall mounting hardware and a manual air vent is supplied with each towel rack.

For piping accessories available through Buderus for a clean, finish installation see Figures 1 and 2.

<i>NB Style towel rack stock sizes</i>				<i>Table 17</i>
<i>Model #</i>	<i>Dimensions (height x width)</i>	<i>BTU @ 180° F</i>	<i>Approx. Ship Wt.</i>	<i>Part NO.</i>
NB towel rack	24" x 32"	2,000	17 lbs. *	NB2432
NB towel rack	24" x 48"	3,000	25 lbs. *	NB2448
NB towel rack	24" x 71"	4,500	35 lbs.	NB2471

* Item can be shipped via UPS

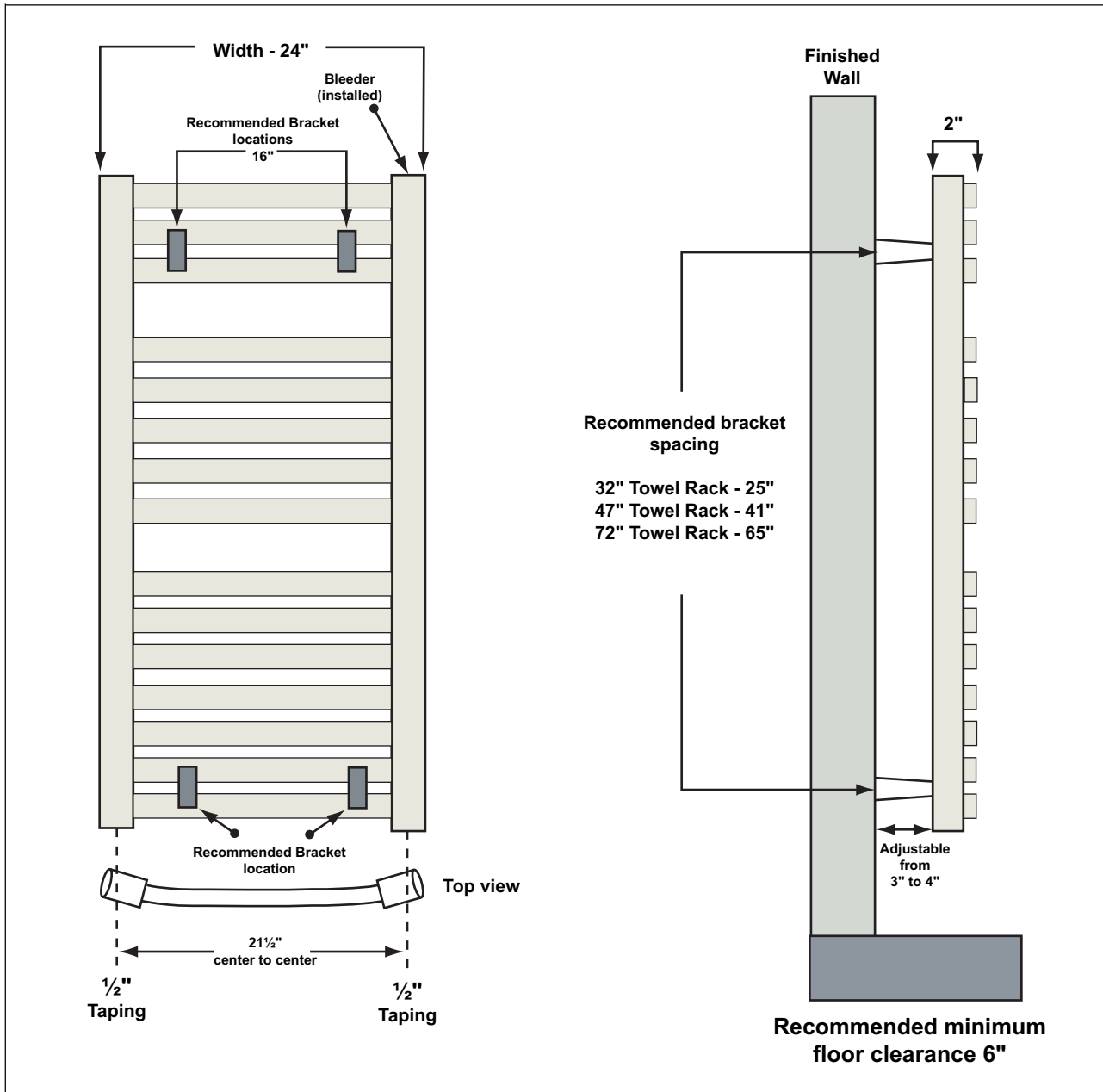

Fig. 15 Buderus NB Style Towel Warmers

- Supply and Return tapings are interchangeable.

Bosch Thermotechnology Corporation
50 Wentworth Avenue
Londonderry, NH 03053
Tel.: 603-552-1100
Fax: 603-584-1681
www.buderus.net

Products manufactured by:
Bosch Thermotechnik GmbH
Sophienstrasse 30-32
D-35576 Wetzlar
www.buderus.de

Bosch Thermotechnology Corporation reserves the right to
make changes without notice due to continuing engineering
and technological advances.

BTC 451001101 A | 12.2009

Buderus

Bosch Group